

Carl Zeiss Compact Prime CP.2

Mount Change Instructions



We make it visible.

A | Adjusting the flange focal distance of the lens



Congratulations on the purchase of this Compact Prime CP.2 lens set. We are convinced that your new lenses will bring you much pleasure and success.

The Compact Prime CP.2 lenses are the latest members of the ZEISS family of lenses for digital and film cameras. They deliver great flexibility by introducing interchangeable mounts that allow the lenses to be used with a wide range of cameras, from traditional cine to HDSLR systems. Available in five different mounts – PL, EF, F, Micro 4/3 and E – this new family of ZEISS lenses enables cinematographers to be completely free in their choice of camera systems. The Compact Prime CP.2 lenses cover the full-frame image format without vignetting.

In this manual we take a Compact Prime CP.2 35mm/ T 2.1 with EF mount, scaled in feet as an example to explain how to change a lens mount and the subsequent matching of your lens to a DSLR camera. Proceed in the same sequences to switch to any other CP.2 mount.

General instructions

- The use of a T6 torque wrench with a torque of 0.4 Nm is strongly recommended. This wrench can be purchased from Carl Zeiss (see appendix, page 17).
- Ensure that the environment is clean and free from dust so that no dust particles can enter the lens during the following procedure.
- Smudges and fingerprints on the lens surface can be gently removed with a soft brush and then with a dry and clean cotton cloth. The ZEISS lens cleaning kit will give superior results and is highly recommended for this purpose.
- When matching the lens, ensure that the colored shims lie on top of each other in the groove of the lens barrel and do not cover the screw holes.
- Please handle the shims carefully as they can easily kink or tear which makes them unusable.

General drawing

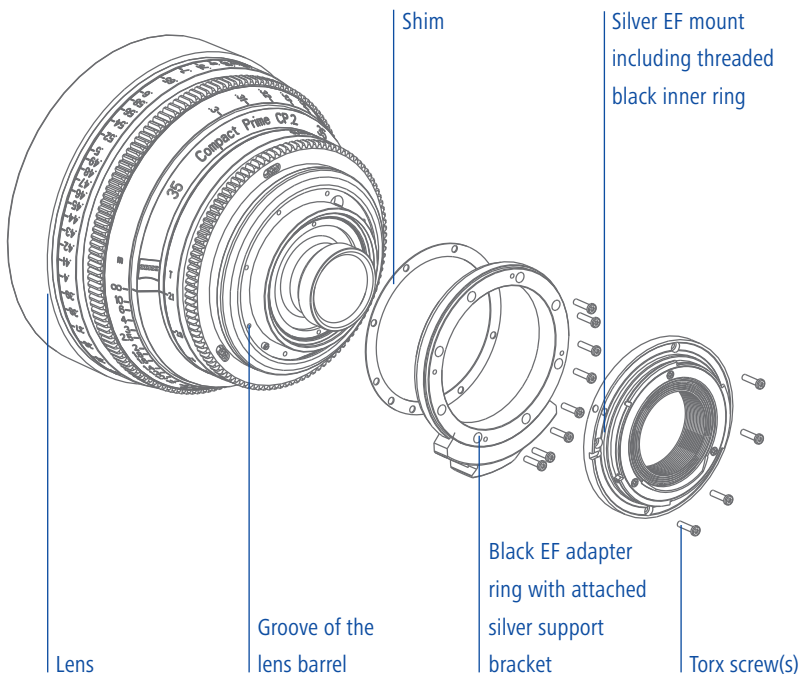

C | Changing the mount

1. Remove the rear lens cap.



2. Remove the four torx screws of the silver EF mount with a T6 torque wrench and place the mount and the screws on one side.
 - The size of the black inner ring depends on the focal length of the lens and is securely fastened to the EF mount (or F, MFT or E Mount) at the factory.



3. Remove the eight torx screws of the black EF adapter ring and place the ring and the screws on one side.
 - The silver support bracket is already installed on the EF adapter ring at the factory and does not need to be removed.



4. Now you see the colored shims in the groove of the black lens barrel.



5. Place the PL mount on the lens in such a way that the groove on the rear side of the PL mount fits over the silver screw on the lens barrel.



6. Tighten the eight torx screws with the T6 torque wrench using a torque of 0.4 Nm.



7. When the torx screws have been tightened, the lens can be fitted to a camera with a PL mount and used.
8. Check the flange focal distance of the lens (see section D) in combination with your camera.

Instructions on changing to an EF or to any other CP.2 mount

1. Ensure that the groove on the rear side of the black EF adapter ring fits over the small screw of the lens barrel.



2. Place the silver EF mount on the EF adapter ring in such a way that the blue dot on the mount has the same orientation as the ZEISS logo and the support bracket points to the serial number on the lens barrel.



3. Please note the correct orientation of the F mount to the ZEISS logo.



4. Please note the correct orientation of the Micro 4/3 and the E mount to the serial number on the lens barrel.



5. Tighten the torx screws using a torque of 0.4 Nm.

D | Adjusting the lens to your camera

As the flange focal distance varies from camera type to camera type, it is necessary to adjust the CP.2 lens to the camera used when changing the mount or camera model (=shimming). In order to perform this adjustment, Carl Zeiss provides shims in different thicknesses that are color coded.

When the mount has been unscrewed, these shims can be placed in a groove in the lens barrel. Any possible combination of shims can be used to achieve the required thickness and therefore the required flange focal distance. The lens already contains shims when delivered.

- Carl Zeiss recommends that the camera is set to the usual standard settings (cf. works settings). You can obtain further details from the instruction manual of the camera you use.

Procedure

In the following chapter we explain how to adjust your Compact Prime CP.2 to a DSLR camera.

1. Fasten the Carl Zeiss test chart on a wall at the appropriate test distance (see tables on page 12 – 16; the test distance is depending on the focal length) and ensure that the illumination is bright and uniform.
2. Mount the camera and lens on a tripod and level the camera, making sure that the centre of the image is aligned with the centre of the Siemens star.



3. Activate the live view of your camera, select the maximum magnification.
4. Set the distance ring to the test distance according to the tables in the appendix. This setting must not be changed during the adjustment process.
5. Set the aperture of the lens to full speed.
6. Obtain maximum image sharpness on the live view by varying the distance between the test chart and the camera.
7. Now remeasure the distance between the image plane mark on the camera body and the test chart (= the actual distance).

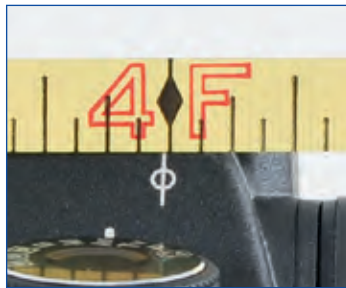

8. If the distance has changed, the flange focal distance of the lens must be adjusted by using the colored shims.
 - You find a list of tables in the appendix for each focal length to calculate the resultant change of the flange focal distance.
9. Now remove the lens from the camera.



10. Remove the EF mount and EF adapter ring (cf. section C 2–4).

11. Determine the total thickness of the shims that are already installed in the lens groove. Increase or decrease the total shim thickness according to the tables in the appendix by using a flat-bladed screw-driver or a pair of tweezers.



12. Place the black EF adapter ring on the lens barrel and tighten the screws using a torque of 0.4 Nm.



13. The next step is to place the silver EF mount on the EF adapter ring and tighten the screws using a torque of 0.4 Nm.



14. Recheck the flange focal distance of the lens (see section D) in combination with the camera you use.

Table for shims to adjust Compact Prime CP.2 lenses when used on digital cameras

| Shim color | Thickness [mm] |
|--------------|----------------|
| silver | 0.013 |
| gold | 0.019 |
| purple | 0.025 |
| light blue | 0.032 |
| red | 0.038 |
| blue | 0.051 |
| white | 0.064 |
| green | 0.076 |
| orange | 0.102 |
| light purple | 0.127 |
| clear | 0.152 |

Example

- Using a Compact Prime CP.2 35mm/T2.1 lens with an EF mount, scaled in feet and a test chart at a test distance of 4 ft, an actual distance of 4 ft 1' is measured. Due to the table on page 14, a silver shim 0.013 mm must therefore be added to the total thickness of the shims.

Note

- Any combination of shims is possible to achieve the required thickness and therefore the desired flange focal distance.
- Always use the closest possible combination of shims.

Tables for adjusting the flange focal distance of Compact Prime CP.2 lenses

All Compact Prime CP.2 lenses cover the full-frame image format (24 x 36 mm), ANSI Super 35 and Normal 35 image format, except the CP.2 18mm/T3.6. This lens covers the ANSI Super 35 and Normal 35 image format.

Key

- **Minus sign:** Shims must be removed
- **Plus sign:** Shims must be added

Compact Prime CP.2 18/T3.6

| Meter distance scale | | Feet distance scale | |
|-------------------------------------|--------------------------------------|-------------------------------------|--------------------------------------|
| Distance to test chart [mm]: 1000 | | Distance to test chart [ft]: 4 | |
| Object distance at best focus [mm]: | Change of total shim thickness [mm]: | Object distance at best focus [ft]: | Change of total shim thickness [mm]: |
| 900 | -0.04 | 3ft 8' | -0.03 |
| 925 | -0.03 | 3ft 9' | -0.02 |
| 950 | -0.02 | 3ft 10' | -0.01 |
| 975 | -0.01 | 3ft 11' | -0.01 |
| 1000 | 0.00 | 4ft 0' | 0.00 |
| 1025 | +0.01 | 4ft 1' | +0.01 |
| 1050 | +0.02 | 4ft 2' | +0.01 |
| 1075 | +0.03 | 4ft 3' | +0.02 |
| 1100 | +0.04 | 4ft 4' | +0.03 |

Compact Prime CP.2 21/T2.9

| Meter distance scale | | Feet distance scale | |
|-------------------------------------|--------------------------------------|-------------------------------------|--------------------------------------|
| Distance to test chart [mm]: 1000 | | Distance to test chart [ft]: 4 | |
| Object distance at best focus [mm]: | Change of total shim thickness [mm]: | Object distance at best focus [ft]: | Change of total shim thickness [mm]: |
| 940 | -0.04 | 3ft 8' | -0.04 |
| 955 | -0.03 | 3ft 9' | -0.03 |
| 970 | -0.02 | 3ft 10' | -0.02 |
| 985 | -0.01 | 3ft 11' | -0.01 |
| 1000 | 0.00 | 4ft 0' | 0.00 |
| 1015 | +0.01 | 4ft 1' | +0.01 |
| 1030 | +0.02 | 4ft 2' | +0.02 |
| 1045 | +0.03 | 4ft 3' | +0.03 |
| 1060 | +0.04 | 4ft 4' | +0.04 |

Compact Prime CP.2 25/T2.9

| Meter distance scale | | Feet distance scale | |
|-------------------------------------|--------------------------------------|-------------------------------------|--------------------------------------|
| Distance to test chart [mm]: 1000 | | Distance to test chart [ft]: 4 | |
| Object distance at best focus [mm]: | Change of total shim thickness [mm]: | Object distance at best focus [ft]: | Change of total shim thickness [mm]: |
| 960 | -0.03 | 3ft 8' | -0.05 |
| 970 | -0.02 | 3ft 9' | -0.04 |
| 980 | -0.02 | 3ft 10' | -0.03 |
| 990 | -0.01 | 3ft 11' | -0.01 |
| 1000 | 0.00 | 4ft 0' | 0.00 |
| 1010 | +0.01 | 4ft 1' | +0.01 |
| 1020 | +0.02 | 4ft 2' | +0.03 |
| 1030 | +0.02 | 4ft 3' | +0.04 |
| 1040 | +0.03 | 4ft 4' | +0.05 |

Compact Prime CP.2 28/T2.1

| Meter distance scale | | Feet distance scale | |
|-------------------------------------|--------------------------------------|-------------------------------------|--------------------------------------|
| Distance to test chart [mm]: 1000 | | Distance to test chart [ft]: 4 | |
| Object distance at best focus [mm]: | Change of total shim thickness [mm]: | Object distance at best focus [ft]: | Change of total shim thickness [mm]: |
| 960 | -0.04 | 3ft 10' | -0.03 |
| 970 | -0.03 | 3ft 10 1/2' | -0.03 |
| 980 | -0.02 | 3ft 11' | -0.02 |
| 990 | -0.01 | 3ft 11 1/2' | -0.01 |
| 1000 | 0.00 | 4ft 0' | 0.00 |
| 1010 | +0.01 | 4ft 1' | +0.01 |
| 1020 | +0.02 | 4ft 1 1/2' | +0.02 |
| 1030 | +0.03 | 4ft 2' | +0.03 |
| 1040 | +0.04 | 4ft 2 1/2' | +0.03 |

Compact Prime CP.2 35/T2.1

| Meter distance scale | | Feet distance scale | |
|-------------------------------------|--------------------------------------|-------------------------------------|--------------------------------------|
| Distance to test chart [mm]: 1000 | | Distance to test chart [ft]: 4 | |
| Object distance at best focus [mm]: | Change of total shim thickness [mm]: | Object distance at best focus [ft]: | Change of total shim thickness [mm]: |
| 980 | -0.03 | 3ft 10' | -0.05 |
| 985 | -0.02 | 3ft 10 1/2' | -0.04 |
| 990 | -0.02 | 3ft 11' | -0.03 |
| 995 | -0.01 | 3ft 11 1/2' | -0.01 |
| 1000 | 0.00 | 4ft 0' | 0.00 |
| 1005 | +0.01 | 4ft 1' | +0.01 |
| 1010 | +0.02 | 4ft 1 1/2' | +0.03 |
| 1015 | +0.02 | 4ft 2' | +0.04 |
| 1020 | +0.03 | 4ft 2 1/2' | +0.05 |

Compact Prime CP.2 50/T2.1 and CP.2 50/T2.1 Makro

| Meter distance scale | | Feet distance scale | |
|-------------------------------------|--------------------------------------|-------------------------------------|--------------------------------------|
| Distance to test chart [mm]: 1500 | | Distance to test chart [ft]: 5 | |
| Object distance at best focus [mm]: | Change of total shim thickness [mm]: | Object distance at best focus [ft]: | Change of total shim thickness [mm]: |
| 1480 | -0.03 | 4ft 11' | -0.03 |
| 1485 | -0.02 | 4ft 11 1/4' | -0.03 |
| 1490 | -0.01 | 4ft 11 1/2' | -0.02 |
| 1495 | -0.01 | 4ft 11 3/4' | -0.01 |
| 1500 | 0.00 | 5ft 0' | 0.00 |
| 1505 | +0.01 | 5ft 1/4' | +0.01 |
| 1510 | +0.01 | 5ft 1/2' | +0.02 |
| 1515 | +0.02 | 5ft 3/4' | +0.03 |
| 1520 | +0.03 | 5ft 1' | +0.03 |

Compact Prime CP.2 85/T2.1

| Meter distance scale | | Feet distance scale | |
|-------------------------------------|--------------------------------------|-------------------------------------|--------------------------------------|
| Distance to test chart [mm]: 1500 | | Distance to test chart [ft]: 5 | |
| Object distance at best focus [mm]: | Change of total shim thickness [mm]: | Object distance at best focus [ft]: | Change of total shim thickness [mm]: |
| 1492 | -0.03 | 4ft 11 4/8' | -0.05 |
| 1494 | -0.02 | 4ft 11 5/8' | -0.04 |
| 1496 | -0.02 | 4ft 11 6/8' | -0.02 |
| 1498 | -0.01 | 4ft 11 7/8' | -0.01 |
| 1500 | 0.00 | 5ft 0' | 0.00 |
| 1502 | +0.01 | 5ft 1/8' | +0.01 |
| 1504 | +0.02 | 5ft 2/8' | +0.02 |
| 1506 | +0.02 | 5ft 3/8' | +0.04 |
| 1508 | +0.03 | 5ft 4/8' | +0.05 |

Compact Prime CP.2 100/T2.1 CF

| Meter distance scale | | Feet distance scale | |
|-------------------------------------|--------------------------------------|-------------------------------------|--------------------------------------|
| Distance to test chart [mm]: 2000 | | Distance to test chart [ft]: 7 | |
| Object distance at best focus [mm]: | Change of total shim thickness [mm]: | Object distance at best focus [ft]: | Change of total shim thickness [mm]: |
| 1987 | -0.04 | 6ft 11 4/8' | -0.03 |
| 1990 | -0.03 | 6ft 11 5/8' | -0.02 |
| 1993 | -0.02 | 6ft 11 6/8' | -0.02 |
| 1997 | -0.01 | 6ft 11 7/8' | -0.01 |
| 2000 | 0.00 | 7ft 0' | 0.00 |
| 2003 | 0.01 | 7ft 1/8' | 0.01 |
| 2007 | 0.02 | 7ft 2/8' | 0.02 |
| 2010 | 0.03 | 7ft 3/8' | 0.03 |
| 2013 | 0.04 | 7ft 4/8' | 0.03 |

Compact Prime CP.2 – Accessories and spare parts

All interchangeable mount sets include: mount, lens caps, adaption ring with support bracket, screws and a set of shims CP.2.

| Accessories/spare parts | | Ident-No. |
|-------------------------|---|-----------|
| EF mount | Interchangeable Mount Set EF (for CP.2 18/T3.6 or CP.2 25/T2.9) | 1849-490 |
| | Interchangeable Mount Set EF (for CP.2 21/T2.9 or CP.2 28/T2.1 or CP.2 35/T2.1) | 1846-492 |
| | Interchangeable Mount Set EF (for CP.2 50/T2.1 or CP.2 85/T2.1) | 1846-494 |
| | Interchangeable Mount Set EF (for CP.2 50/T2.1 Makro) | 1846-496 |
| | Interchangeable Mount Set EF (for CP.2 100/T2.1 CF) | 1846-499 |
| PL mount | Interchangeable Mount Set PL (for CP.2 18/T3.6 or CP.2 25/T2.9) | 1846-489 |
| | Interchangeable Mount Set PL (for CP.2 21/T2.9 or CP.2 28/T2.1 or CP.2 35/T2.1) | 1846-491 |
| | Interchangeable Mount Set PL (for CP.2 50/T2.1 or CP.2 85/T2.1) | 1846-493 |
| | Interchangeable Mount Set PL (for CP.2 50/T2.1 Makro) | 1846-495 |
| | Interchangeable Mount Set PL (for CP.2 100/T2.1 CF) | 1846-498 |

| Accessories/spare parts | | Ident-No. |
|-------------------------|--|-----------------|
| F mount | Interchangeable Mount Set F (for CP.2 18/T3.6 or CP.2 25/T2.9) | 1871-042 |
| | Interchangeable Mount Set F (for CP.2 21/T2.9 or CP.2 28/T2.1 or CP.2 35/T2.1) | 1871-043 |
| | Interchangeable Mount Set F (for CP.2 50/T2.1 or CP.2 85/T2.1 or CP.2 50/T2.1 Makro) | 1871-046 |
| | Interchangeable Mount Set F (for CP.2 100/T2.1 CF) | 1871-044 |
| Micro 4/3 mount | Interchangeable Mount Set MFT (for CP.2 18/T3.6 or CP.2 25/T2.9) | 1889-230 |
| | Interchangeable Mount Set MFT (for CP.2 21/T2.9 or CP.2 28/T2.1 or CP.2 35/T2.1) | 1889-231 |
| | Interchangeable Mount Set MFT (for CP.2 50/T2.1 or CP.2 85/T2.1) | 1889-232 |
| | Interchangeable Mount Set MFT (for CP.2 50/T2.1 Makro) | 1889-233 |
| | Interchangeable Mount Set MFT (for CP.2 100/T2.1 CF) | 1889-234 |
| E mount | Interchangeable Mount Set E (for CP.2 18/T3.6 or CP.2 25/T2.9) | 1907-608 |
| | Interchangeable Mount Set E (for CP.2 21/T2.9 or CP.2 28/T2.1 or CP.2 35/T2.1) | 1907-609 |
| | Interchangeable Mount Set E (for CP.2 50/T2.1 or CP.2 85/T2.1) | 1907-610 |
| | Interchangeable Mount Set E (for CP.2 50/T2.1 Makro) | 1907-611 |
| | Interchangeable Mount Set E (for CP.2 100/T2.1 CF) | 1907-612 |
| | CP.2 Transport Case (external dimensions: 56 x 45.5 x 26.5 cm (22.06" x 17.93" x 10.43")) | 1856-822 |
| | Support Bracket EF, F, MFT, E (incl. screws) | 1856-667 |
| | Torx torque wrench (T6, torque moment 0.4 Nm) | 0520-065 |
| | Torx Pan-Head screw (M2 x 8 -SUS 410; 50 pcs.) | 500-022 |
| | Front Lens Cap EF, PL, F, MFT, E | 0097-227 |
| | Rear Lens Cap EF | 1793-167 |
| | Rear Lens Cap PL | 102160-0052-000 |
| | Rear Lens Cap F | 1793-178 |
| | Rear Lens Cap MFT | 1889-118 |
| | Rear Lens Cap E | 1907-145 |
| | Siemens Star test chart (DIN A3, laminated) | 1849-755 |
| | Set of shims CP.2 | 1853-634 |

For further information, please contact us:

Carl Zeiss AG

Camera Lens Division

73446 Oberkochen

Germany

cine@zeiss.de

www.zeiss.com/cine